

SUPERPRESSURE

MOTOR DRIVEN DIAPHRAGM-TYPE COMPRESSORS

46-13411-2	SINGLE ENDED	10K PSI
46-13416-2	SINGLE ENDED	30K PSI
46-13418	DOUBLE ENDED	30K PSI
46-13421-2	DOUBLE ENDED	10K PSI
46-13427-2	TWO STAGE	10K & 30K PSI
46-13429	TWO STAGE	6K & 10K PSI
46-13435	TWO STAGE	6K & 30K PSI
46-13484	SINGLE ENDED	6K PSI
46-13487	DOUBLE ENDED	6K PSI

This Manual is for:

Compressor Part No. : _____
Sales Order No. : _____
Serial No. : _____
Date Manufactured : _____
System Part No. : _____

NEWPORT SCIENTIFIC, INC
8246-E SANDY COURT
JESSUP, MD 20794
PHONE: 301-498-6700 FAX: 301-490-2313
EMAIL: sales@newport-scientific.com
WEB SITE: www.newport-scientific.com

CONTENTS

- I. INSPECTION
- II. INTRODUCTION
- III. PRINCIPLES OF OPERATION
- IV. PERFORMANCE CHARACTERISTICS & SPECIFICATIONS
- V. INSTALLATION
 - a. Electrical Requirements
 - b. Space Requirements
 - c. Gas/Liquid Service Conversion
 - d. Installation Procedure
- VI. OPERATION
 - a. Priming Procedure
 - b. Verify Check Valve Operation
- VII. TROUBLESHOOTING
- VIII. WARNINGS, PERCAUTIONS, & LIMITATIONS
- IX. MAINTENANCE
 - a. Periodic Maintenance,
 - b. Adjustment of Pressure Limiting Device
 - c. Crank Stroke Adjustment
 - d. Corrective Maintenance
- X. RECOMMENDED SPARE PARTS
- XI. ASSEMBLY DRAWINGS & CAPACITY CURVES – SEE LIST

I. INSPECTION

If damage is discovered upon unpacking the equipment, an immediate request should be forwarded to the delivering carrier to perform an inspection and prepare a concealed-damage report. Concurrently, the nature and extent of damage should be reported to Newport Scientific, Inc., giving catalog and serial numbers, so that action may be initiated to replace damaged parts, or instructions issued for the return of the apparatus.

II. INTRODUCTION

The Superpressure Diaphragm-Type Gas Compressors handle fluids of all types with absolute purity. The fluid being compressed comes into contact only with clean, dry, corrosion-resistant metallic surfaces. The compressors are suited for all types of laboratory applications as well as for pilot plant and industrial applications requiring low gas flows. The compressors operate at a 14 to 1 maximum compression ratio and are designed to circulate or boost gas from a low pressure to pressures of 6,000, 10,000, or 30,000 psi. These compressors may be used for testing and calibration of critical devices such as missile system components, etc., where hydrostatic pressure testing and calibration would be difficult or impossible.

These compressors may be easily cleaned. Fluids other than ordinary oil, such as oxygen-compatible fluorinated products, may be used for diaphragm pulsing if required for specific applications. Compressors can be constructed of materials other than those normally supplied for particular corrosion-resistant applications on special order. The compressors when specifically cleaned and serviced, are also used for oxygen service.

These compressors are adaptable to either gas or intermittent liquid service. Changeover from one to the other is accomplished by interchanging a set of intake and exhaust check valves. Single or double ball check valves are available from Newport Scientific, Inc. which enable the compressors to be used for intermittent liquid service.

III. PRINCIPLES OF OPERATION

The plunger of the compression head is reciprocated as in a pump. Oil from the storage bulb is compressed by the plunger, which in turn pulses the diaphragm. The fluid to be compressed is taken in and discharged on the opposite side of the diaphragm through the check valves in the head plate on the down and up stroke of the diaphragm. Oil is drawn into the chamber beneath the diaphragm by the suction created on the plunger backstroke. Excess oil in the chamber can flow back to the storage bulb during the forward plunger stroke through the pressure limiting device. This built-in hydraulic device is manually adjustable and ensures that the discharge pressure of the compressor cannot exceed a preset limit. The plunger stroke is preset so that under normal operating conditions, oil will not flow through the pressure limiting device unless the maximum discharge pressure is exceeded.

IV. PERFORMANCE CHARACTERISTICS AND SPECIFICATIONS

CHARACTERISTICS:

- Contamination-free gas compression.
- Parts in contact with gas are made of the following materials:
- Upper head plates, 17-4PH SS; Valves, 302, 304, 316, 17-4PH SS and Nylon 101; Diaphragms, 302 SS.
- Compressor is suitable for suction at constant or continually varying suction pressures up to the maximum permissible discharge pressure.
- Compression ratios of up to 14-to-1 are obtainable for each stage.
- Diaphragm life in excess of 500 hours of operation normally attained.
- Absence of stuffing box permits leak-free operation.
- Elastomer packing provides a leak-free oil seal, long life and never needs tightening.
- Interchangeable check valves permit either continuous gas or intermittent liquid service.
- Check valves can be easily removed for cleaning and replacement.
- Floating hydraulic plunger ensures minimum wear on packing.

SPECIFICATIONS: All compressor intake and discharge check valve openings (female) are for ¼ inch O.D. Superpressure tubing.

MOTOR-DRIVEN DIAPHRAGM COMPRESSOR SPECIFICATIONS

	SINGLE-END			DOUBLE-END		TWO STAGE		
CATALOG NUMBER	46-13484	46-13411-2	46-13416-2	46-13487	46-13421-2	46-13427-2	46-13429	46-13435
MAX. WORKING PRESSURE (PSI)	6,000	10,000	30,000	6,000	10,000	30,000	10,000	30,000
MIN. WORKING PRESSURE (PSI)	150	150	150	150	150	50	50	50
PLUNGER DIA. (IN.)	3/4	9/16	3/8	3/4	9/16	9/16,3/8	3/4, 9/16	3/4,3/8
STROKE, NOMINAL (IN.)	7/8	1-1/16	7/8	7/8	1-1/16	1-1/16	1-1/16	1-1/16
STROKES / MINUTE	58	58	58	58	58	58	58	58
VOLUME AT ATMOS. PRESSURE (XU. IN./STROKE)	.36	.26	.10	.72	.52	.36	.62	.46
WEIGHT (LB.) NET/SHIPPING	245/295	238/289	254/305	285/335	270/320	286/327	286/327	286/327
OVERALL DIM. L X W X H (IN.)	20 X 22 X 19			29 X 22 X 19				
MOUNTING DATA	4 HOLES, 9/16 DIA. ON 13 X 14-1/4 CENTERS							
MOTOR CHARACTERISTICS	1 HP, 1800 RPM, 230/460 VOLT, 3 PHASE, 60 HZ, EXPLOSION PROOF, W/58 RPM SPEED REDUCER							
PORTS, WORKING FLUID INLET; OUTLET	¼ O.D. TUBING; ¼ O.D. TUBING							

V. INSTALLATION

Installation requirements, installation procedures, and checkout procedures are contained in this section.

ELECTRICAL REQUIREMENTS

Motors for the motor-driven compressors require 208-220 or 440V, 3-phase, 60 Hz power. This power must be connected by an electrician in accordance with local and national electrical code regulations. Observe the directions provided on the instruction plate attached to the motor.

SPACE REQUIREMENTS

These compressors require the following minimum area: L 35 x W 21 x H 21 inches.

GAS/LIQUID SERVICE CONVERSION

These compressors can be adapted for intermittent liquid service. To convert from gas to intermittent liquid service or vice-versa, replace the set of intake and exhaust check valves on the compressors with the set specified in Table for the particular service application. On the 6,000 and 10,000 psi gas head, for intermittent service with normal liquids, double-ball check valves must be used. Difficult liquids are water, volatile hydrocarbons, low or high-viscosity liquids and liquids containing sediments. On 30,000 psi gas heads, for intermittent liquid service, double-ball check valves must be used for all liquids.

PRECAUTION

****Liquid service check valves CANNOT be used on Two-Stage Compressors.****

ORDERING DATA AND SPECIFICATIONS FOR CHECK VALVES

COMPRESSOR CATALOG NUMBER	QTY	STANDARD GAS CHECK VALVES INLET/DISCHARGE	LIQUID SERVICE SINGLE BALL INLET/DISCHARGE	LIQUID SERVICE DOUBLE BALL INLET/DISCHARGE
46-13411-2 46-13484	1 Ea	44-11102 44-11107	44-14100 44-14115	44-14210 44-14215
46-13421-2 46-13429 46-13487	2 Ea	44-11102 44-11107	44-14100 44-14115	44-14210 44-14215
46-13416-2	1 Ea	44-13100 44-13120		44-13140 44-13160
46-13427-2 46-13435	1 Ea	44-11102 44-11107 44-13100 44-13120		

*Also used where ultra-pure cleaning is required.

Each check valve listed in Table has a ¼ inch O.D. female tubing opening. Special-Inlet Adapter 45-16705 for liquid service can be used with the 44-13140, 44-14100, and 44-14210 Intake Check Valves when a ¼ inch NPT connection is desired. This adapter converts the ¼ inch O.D. female connection to ¼ inch NPT, female.

OXYGEN SERVICE CONVERSION

All compressors can be modified for Oxygen Service. This involves Oxygen-cleaning all parts in contact with the gas, installing a set of Oxygen-service check valves, and replacing the packing. Contact Newport Scientific for details.

INSTALLATION PROCEDURE

Perform the following procedures to install your compressor:

1. Remove cork seal from reservoir.
Remove plastic plugs from the intake and exhaust check valves.
2. Secure compressor through mounting holes.
3. Fill oil reservoir with Oildyne Hydraulic Fluid 15-40 oil, except for oxygen service compressors. Fill oxygen service compressor's oil reservoir with fluorocarbon oil or halocarbon oil.
4. Connect inlet tubing to compressor as follows: When installing or removing tubing, keep all tubing lines and fittings clean. Flush tubing with solvent using a syringe and blow dry with clean air or gas. (Including new tubing.)

PRECAUTION

If dirt enters compressor, the diaphragm and check valves may be damaged.

- A. Install a 5 micron dry-type filter 49-14405 in the inlet tubing line.
- B. Connect inlet tubing line from filter as follows:

-For the single end or two-stage compressor, connect 45-11020 tubing to check valve marked IN on the head.

-For the double-end compressor, connect to the inlet manifold.

5. Connect outlet tubing from Discharge check valve to a pressure relief valve or rupture-disc assembly in accordance with standard ASME practice.

PRECAUTION

A relief valve or rupture-disc must be installed to prevent damage to equipment if an overpressure condition occurs.

Connect outlet tubing from relief valve or rupture disc to system equipment.

6. For motor-driven compressors, connect power line to motor in accordance with local and national electrical code regulations. Observe the power requirements and directions provided on the instruction plate attached to the motor. A switch or circuit breaker should be connected in the power line to enable turning the compressor on and off, as required.

WARNING
IMPROPER WIRING CONNECTIONS COULD PRESENT A SHOCK HAZARD.

7. If necessary, adjust the crank stroke length. The crank length was preset by NEWPORT SCIENTIFIC, INC. and will require readjustment only if:

- the shoe clamping bolts work loose or are intentionally loosened.
- the head assembly is changed.

To adjust the crank stroke length, perform the "Crank Stroke Adjustment Procedure" in Section IX.

8. Checkout the operation of the compressor by performing the procedure in Section VI.

PRECAUTION

Do not run the compressor with no suction pressure, or very low suction pressure, this will cause a build up of oil underneath the diaphragm and will result in the compressor ceasing to pump gas. If this does occur, turn on the gas suction, loosen the lock nut on the pressure limiting device (be sure not to lose the original setting), back off the set screw, and run the compressor to allow the excess oil to re-circulate. The limiter should then be returned to its original setting.

VI. OPERATION

The operating procedures in this section describe how to operate the compressor, how to perform the priming procedure if the compressor fails to build-up pressure, and how to verify proper check valve operation.

PRECAUTION

If dirt enters the compressor, the diaphragm and check valves may be damaged. It is absolutely essential that the incoming gas is filtered. We suggest a 5 or 10 micron in-line Filter such as Cat. # 49-14405.

Also any lines to be placed between the Filter and the compressor should be thoroughly cleaned. Flush with solvent using a syringe, and blow dry with clean air or gas. (Even a new piece of high pressure tubing may contain sufficient particulate matter to foul the check valves).

To operate the motor-driven compressor, turn on electric power to the compressor. Observe the gas discharge pressure to ensure that the compressor is operating properly. If the compressor fails to build-up pressure, shut off power and perform the "Priming Procedure" in the next paragraph.

PRIMING PROCEDURE

To prime the compressor, perform the following:

1. Close off the gas discharge line.
2. Apply suction pressure to the compressor inlet. (The term suction pressure means the positive pressure applied to the compressor inlet, e.g. a minimum suction pressure of 700 psi is recommended for 10,000 psi discharge on 46-13411-2).
3. Add oil to the reservoir if required.
4. Loosen the stop nut on the top of pressure limiting device, being careful not to lose the setting. Reverse the set screw back until it no longer applies tension to the spring. The stop nut will turn with the set screw, thereby maintaining the original Factory setting.
5. Run the compressor. While it is running, loosen the large gland nut at the base of the pressure limiting device by 1-1/2 turns, and pull back on the body of the limiter to release the orifice piece. This removes all force from the seat and allows fresh oil to be pulled in from the reservoir.

The large gland nut should be loosened just for a couple of strokes of the compressor and then retightened. Some oil will be spilled out during the above operation.

6. Return the setscrew to its' original setting and retighten the stop nut.

PROCEDURE FOR VERIFYING PROPER CHECK VALVE OPERATION

1. Install pressure gauges on Compressor Inlet & Outlet, if not already present.
2. Apply suction pressure of 1,000 psi to Compressor Inlet.
3. Operate Compressor.
4. If either gauge fluctuates wildly then remove check valves and clean or replace.

VII. TROUBLESHOOTING

The table below provides guidelines in localizing a compressor malfunction. Refer to "Corrective Maintenance" procedure to replace a component.

Malfunction Indication	Probable Cause	Action
COMPRESSOR OPERATES AND BUILDS-UP PRESSURE BUT OUTPUT VOLUME IS IMPROPER	<ol style="list-style-type: none"> 1.External leakage at check valve or diaphragm. 2.Pressure limiting device setting is too low. Oil level in reservoir changes more than a little on each stroke. 3.Intake or exhaust check valve malfunctioning. 	<ol style="list-style-type: none"> 1.Check for leakage using bubble test. Tighten or replace component as req'd. 2.Perform "Adjustment of Pressure Limiting Device" procedure in Section IX Maintenance. Pressure limiting device should never heat. 3.Perform the "Procedure for Verifying Proper Check Valve Operation" in Section VI, Operation.
COMPRESSOR OPERATES BUT PRESSURE DOES NOT BUILD-UP TO MAXIMUM	<ol style="list-style-type: none"> 1.Inlet Pressure too low. 2.Pressure leakage. 3.Faulty check valve. 4.Compressor is not primed. 5.Defective hydraulic check valve or pressure-limiting device. 	<ol style="list-style-type: none"> 1.Check that compression ratio is 14:1 maximum. 2.Isolate compressor from rest of system and check for pressure leaks. 3.Perform "Procedure for Verifying Proper Check Valve Operation" in Section VI, Operation. 4.Perform "Priming Procedure" in Section VI, Operation. 5.Replace.
BUBBLES IN OIL RESERVOIR	<ol style="list-style-type: none"> 1.Leaking packing. 2.Ruptured Diaphragm(s) 	<ol style="list-style-type: none"> 1.Replace packing according to "Corrective Maintenance" in Section IX, Maintenance. 2.Replace diaphragm(s) according to "Corrective Maintenance" in Section IX, Maintenance.

VIII. WARNINGS, PRECAUTIONS, AND LIMITATIONS

This section summarizes all warnings, precautions, and limitations contained in this manual. The warnings paragraphs list hazards which, if not observed, could lead to personnel injury. The precautions paragraph lists actions which could result in damage to the equipment.

WARNINGS

The power line ground circuit for the motor-driven compressor should be continuous to the main power panel. The panel should be grounded directly to a water pipe or other electrical earth ground. Improper grounding could result in a shock hazard.

When performing maintenance on a motor-driven compressor, disconnect power from compressor and attach a warning label **DO NOT TURN ON SWITCH, MAINTENANCE BEING PERFORMED** to the power switch to ensure against inadvertent start-up of the compressor.

PRECAUTIONS

Liquid service check valves **CANNOT** be used on Two-Stage Compressors.

A relief valve or rupture-disc must be installed in the outlet tubing line to prevent damage to equipment if an overpressure condition occurs.

Ensure that the fluid being compressed is maintained free of solid particulate contaminants. If dirt enters the compressor, the diaphragm and check valves may be damaged.

LIMITATIONS

The pressure-limiting device should be set to an upper limit pressure of approximately 110 percent of the maximum operating pressure.

The pressure limiter on the first stage of a two-stage compressor (46-13427) should be set at 5000 psi and the inter-stage pressure should not exceed 4500 psi for optimum diaphragm life, and for compressors (46-13429 and 46-13435) set at 6,600 psi not to exceed 6,000 psi.

IX. MAINTENANCE

PERIODIC MAINTENANCE

A. Lubrication

This system is designed to automatically lube the drive mechanism. It will provide the right amount of grease to meet lubrication requirements for the Slotted Lever.

This unit should be checked every 3-5 hours of run time on the compressor to determine grease level. To refill Lube Site: Remove fasteners and guard from compressor. Simply refill by attaching the grease gun that is supplied with the unit to the grease fitting. Fill until the seal ring rises to the bottom edge of the "CAUTION" label. **DO NOT OVERFILL**. This should be done before the seal ring is down to the top of the base.

Also, when service is being done on the Lube Site, the pivot pins on the drive unit should be oiled with any 10W 30W or 10W 40W oil.

These instructions will allow the Lube Site to give you many years of trouble-free automatic lubrication.

B. Filter Replacement

If a 49-14405 dry-type filter is installed in the inlet tubing line, periodically replace the filter discs (49-14490, set of four).

ADJUSTMENT OF PRESSURE LIMITING DEVICE

NOTE: The Pressure Limiting Device was preset by Newport Scientific and should never need re-adjustment. This device was set to release oil back to the storage bulb when the discharge pressure reaches 110% of the maximum pressure rating of the compressor. This setting was obtained by turning the setscrew at the top of the pressure limiter until the desired release pressure was obtained.

The setscrew was then held stationary while the outer stop nut was tightened down to the limiter body to lock in the setting. As long as the stop nut is not turned relative to the setscrew, the setscrew can be turned out and in for priming and still maintain the original factory setting.

If the stop nut has been turned relative to the setscrew, the following procedure can be followed to reproduce the original setting.

1. Install pressure gauges in the inlet & outlet lines of the compressor if not already present.
2. Make sure system is primed and check valves are operating properly as per Section VI, Operation.
3. Stop compressor operation.
4. Loosen outer stop nut on top of pressure limiter and turn setscrew back until all tension is removed from the spring.
5. Apply suction pressure of at least 1000 psi.
6. Adjust setscrew slowly inward to obtain the following maximum discharge pressure.
 - for 6,000 psi compressors, set to 6,600 psi
 - for 10,000 psi compressors, set to 11,000 psi
 - for 30,000 psi compressor, set to 33,000 psi

NOTE: For a two stage compressor, set to 5,000 psi on first stage.

NOTE: Outlet pressure gauge needle will fluctuate slightly with each piston stroke, using the highest reading on each stroke when setting the pressure.

7. Hold setscrew stationary and tighten outer stop nut to lock in pressure setting.

NOTE: It is not recommended that the pressure limiter be set at a pressure lower than the original factory setting. If it is desired to maintain the system at a lower pressure, to prevent over-pressurization of components, the following configuration is recommended.

CRANK STROKE ADJUSTMENT PROCEDURE

On Motor-Driven Compressors, the piston stroke length is preset by Newport Scientific and must be re-adjusted if:

- The slide block clamping bolts work loose or are intentionally loosened.
- The head assembly or packing are changed.

NOTE: The pressure limiter adjustment need not be changed unless the original factory setting was lost according to the last section on Adjustment of the Pressure Limiting Device. If the pressure limiter and the crank stroke both need adjustment, they must be performed simultaneously according to No. 11 of this section.

For maximum compressor efficiency, the volume of oil displaced is critical. This volume is proportional to the length of the piston stroke, and the adjustment procedure is the same for all compressors and all piston sizes. –Refer to Section IV, Specifications.

1. Stop compressor operation. Disconnect power and attach a warning label (“DO NOT TURN ON SWITCH, MAINTENANCE BEING PERFORMED”) to the power switch to assure against inadvertent start-up of the compressor.
2. Remove guard.
3. Crack tubing gland nut on discharge check valve(s) to release system pressure. Re-tighten gland nut(s).
4. Bring crank to the vertical position. Rotate the motor armature by inserting a metal rod through the cooling slots in the rear of the motor and carefully turning the fan blades until crank is in the vertical position.
5. Loosen the two (2) slide block clamping bolts on the crank.
6. While crank is in vertical position, adjust the dimension to a distance between the bottom of the slot in the crank and the end of the slide block to approximately 7/16 inch. Tighten the two (2) slide block clamping bolts to 50-60 ft-lbs torque.
7. Place a piece of masking tape on the slotted lever beside the slide block and mark the position of the slide block with a pencil.
8. Apply suction pressure of at least 1000 psi.

9. Operate the compressor with the discharge dead-ended on a pressure gauge.
10. Make sure compressor is primed and that check valves are operating properly.
11. The slide block adjustment "A" of 7/16 inch was deliberately set in the high range to cause over stroking of the compressor. Over stroking is present when the oil level in the oil reservoir rises and falls before 110% of the maximum pressure is reached. While compressor is over stroking, pressure should build up to 110% of the maximum operating pressure.

<u>Maximum Operating Pressure</u>	<u>110%</u>
6,000 psi	6,600 psi
10,000 psi	11,000 psi
30,000 psi	33,000 psi

NOTE: The pressure limiter on the first stage of a two-stage compressor should be set at 5,000 psi and the interstage pressure should not exceed 4500 psi for optimum diaphragm life.

If the pressure obtained is lower or higher than that shown above, then adjust the pressure limiter according to the Adjustment of Pressure Limiting Device earlier in this section.

12. With pressure limiter set at proper pressure, adjust the crank dimension "A" to obtain optimum stroke. Optimum stroke is obtained when oil level just begins to rise and fall as 110% of maximum pressure is reached.
13. Stop compressor operation.
14. Bring crank to vertical position and loosen bolts according to steps 3, 4, and 5.
15. Adjust slide block downward in increments of 1/32 inch from the last setting and tighten bolts to 50-60 ft-lb. Mark new position of slide block.
16. Operate the compressor.
17. Check for over stroking according to step 11. If compressor is still over stroking, repeat steps 13 through 17 until optimum stroke is achieved.

NOTE: Compressor is under stroking when pressure fails to build up to 110% of the maximum pressure.

18. Replace guard.

CORRECTIVE MAINTENANCE

The following paragraphs describe how to replace the check valves, the diaphragm, the packing and the pressure-limiting device.

WARNING

ON MOTOR-DRIVEN COMPRESSORS, DISCONNECT POWER FROM COMPRESSOR AND ATTACH A WARNING LABEL ("DO NOT TURN ON SWITCH, MAINTENANCE BEING PERFORMED") TO THE POWER SWITCH TO ENSURE AGAINST INADVERTENT START-UP OF UNIT.

Check Valve Replacement

1. Stop compressor operation.
2. Release pressure from tubing lines.
3. Disconnect tubing connected to check valve.
4. Remove check valve.
5. Examine check valve for foreign particles, wear or damage. Replace with new check valve, if required.
6. Install check valve on compressor. Ensure that the lens rings are properly seated. Improper seating of the lens rings may result in a leaking check valve.

Diaphragm Replacement

1. Stop compressor operation.
2. Release pressure from system and tubing lines to compressor.
3. Close off intake and discharge lines.
4. Crack connection to check valves to allow trapped pressurized fluid to escape, then disconnect all gas lines.
5. Support head and remove the four (4) caps screws which secure it to the frame.
6. Pull head straight back, being careful not to scratch the piston which will remain connected to the drive assembly.
7. Secure hydraulic section in a clamping device.
8. Remove head bolts and pull the head plate. Inspect the head for damage. Clean head and cover with a protective cloth.
9. Remove the check valves, inspect, clean and cover with a protective cloth.

10. Remove diaphragm. The 6,000 psi and 10,000 psi compressor heads have one (1) diaphragm per head. The 30,000 psi compressor heads have two (2) diaphragms per head.
11. Thoroughly clean and install new diaphragm(s).
12. Reinstall head, head bolts, and check valves. Lubricate head's washer and bolt threads with bearing grease when compressor is used for normal fluids. When used for oxygen service, use fluorocarbon grease. Reinstall all tubing removed (use check valves as guide for proper tubing installation).
13. Hand-tighten all the head bolts, using a torque wrench. Sequentially tighten OPPOSING head bolts in 10 ft-lb increments to a final torque of:
 - 150 ft-lbs for 6,000 psi and 10,000 psi compressor heads
 - 350 ft-lbs for 30,000 psi compressor heads
14. Attach all gas connections.
15. Perform the "Priming Procedure" in Section VI, Operation.

Packing Replacement

1. Perform Steps 1 through 9 of Diaphragm Replacement (above).
2. Remove packing and clean packing cavity.
3. Replace worn packing components according to the spare parts list.
4. Perform steps 13 through 16 of diaphragm replacement.

Pressure-Limiting Device Replacement

1. Stop compressor operation.
2. Release pressure from system and tubing lines to compressor.
3. Crack connection at bottom of pressure-limiting device to allow trapped pressurized fluid to escape.
4. Hold body of pressure-limiting device with one (1) wrench while unscrewing gland nut with another wrench, Figure 5-1.
5. Unscrew orifice 62006001001, 2 or 4 by wrenching at the flats or the seat.
6. Replace the pressure limiting device (62006001201 or 62006001202) or parts, as required.
7. Reassemble and reinstall on compressor.

X. RECOMMENDED SPARE PARTS

DESCRIPTION	CAT. NO OR PART NO.	46- 13411-2	46- 13416-2	46- 13421-2	46- 13427-2	46- 13429	46- 13435	46- 13484	46- 13487
CHECK VALVE, HYDRAULIC	44-14110	1	1	2	2	2	2	1	2
CHECK VALVE, INTAKE	44-11102	1		2	1	2	1	1	2
CHECK VALVE, DISCHARGE	44-11107	1		2	1	2	1	1	2
CHECK VALVE, INTAKE	44-13100		1		1		1		
CHECK VALVE, DISCHARGE	44-13120		1		1		1		
DIAPHRAGM	62018000500	1	2	2	3	1	2		
DIAPHRAGM	84001001100					1	1	1	2
OILER	P1004002900	1	1	2	2	2	2	1	2
SOFTGOOD PACKING KIT	85001000900	1		2	1	1			
SOFTGOOD PACKING KIT	85001000500		1		1		1		
SOFTGOOD PACKING KIT	85001001100					1	1	1	2
PACKING RETAINER	64042002500	1		2	1	1	1		
PACKING RETAINER	65013002700		1		1				
PACKING RETAINER	84001000800					1	1	1	2
PACKING FOLLOWER	64042002200	1		2	1	1	1		
PACKING FOLLOWER	65013002800		1		1				
PACKING FOLLOWER	84001000700					1	1	1	2
½" DIA PISTON ASSEMBLY FROM POLY-PACK TO LEATHER PACKING SEE DRAWING # 85001001300									

XI. ASSEMBLY DRAWINGS & CAPACITY CURVES

COMPRESSOR # 46-13411-2 MOTOR DRIVEN SINGLE ENDED 10K PSI

46-13411-2	Compressor Assembly Sheet
64042002702	Head & Drive Assembly Single Acting
64042002802	Head Assembly (Left Side) 10,000 PSI
84001000400	Drive Piston Assembly
44-11102	Intake Check Valve 10,000 PSI
44-11107	Discharge Check Valve 10,000 PSI
44-14110	Inlet Check Valve Single Ball
62006001200	Assembly Relief Valve-Liquid Service
Curve 10K Motor	Capacity Curve

COMPRESSOR # 46-13418 MOTOR DRIVEN DOUBLE ENDED 30K PSI

46-13418	Compressor Assembly Sheet
73064000302	Head & Drive Assembly Double Acting
65013000502	Head Assembly Left Side 30,000 PSI
65013000602	Head Assembly Right Side 30,000 PSI
84002000400	Drive Piston Assembly
44-13100	Intake Check Valve 30,000 PSI
44-13120	Discharge Check Valve 30,000 PSI
44-14110	Inlet Check Valve Single Ball
62006001200	Assembly Relief Valve – Liquid Service
Curve 30K Motor	Capacity Curve

COMPRESSOR # 46-13421-2 MOTOR DRIVEN DOUBLE ENDED 10K PSI

46-13421-2	Compressor Assembly Sheet
64042002902	Head & Drive Assembly Double Acting
64042002602	Head Assembly 10,000 PSI
64042002802	Head Assembly 10,000 PSI
84002000400	Drive Piston Assembly
44-11102	Intake Check Valve 10,000 PSI
44-11107	Discharge Check Valve 10,000 PSI
44-14110	Inlet Check Valve Single Ball
62006001200	Assembly Relief Valve-Liquid Service
Curve 10K Motor	Capacity Curve

COMPRESSOR # 46-13427-2 MOTOR DRIVEN TWO STAGE 10 & 30K PSI

46-13427-2	Compressor Assembly Sheet
73064000202	Head & Drive Piston Assembly
44-11102	Intake Check Valve 10,000 PSI
44-11107	Discharge Check Valve 10,000 PSI
44-13100	Intake Check Valve 30,000 PSI
44-13120	Discharge Check Valve 30,000 PSI
64042002602	Head Assembly 10,000 PSI
65013000502	Head Assembly 30,000 PSI Left Side
44-14110	Inlet Check Valve Single Ball
62006001200	Assembly Relief Valve – Liquid Service
Curve 1030 Motor	Capacity Curve

COMPRESSOR # 46-13429 MOTOR DRIVEN TWO STAGE 6 & 10K PSI

46-13429	Compressor Assembly Sheet 1
84002000300	Head & Drive Piston Assembly
64042002802	Head Assembly 10,000 PSI
84001001500M	Head Assembly 6,000 PSI
84002000400	Drive Piston Assembly
44-11102	Intake Check Valve 10,000 PSI
44-11107	Discharge Check Valve 10,000 PSI
44-14110	Inlet Check Valve Single Ball
62006001200	Assembly Relief Valve-Liquid Service
Curve 610 Motor	Capacity Curve

COMPRESSOR # 46-13435 MOTOR DRIVEN TWO STAGE 6 & 30K PSI

46-13435	Compressor Assembly Sheet
84002000600	Head & Drive Piston Assembly
84001001500	Head Assembly 6,000 PSI
65013000502	Head Assembly 30,000 PSI
84002000400	Drive Piston Assembly
44-11102	Intake Check Valve 10,000 PSI
44-11107	Discharge Check Valve 10,000 PSI
44-13100	Inlet Check Valve 30,000 PSI
44-13120	Discharge Check Valve 30,000 PSI
62006001200	Assembly Relief Valve-Liquid Service
Curve 630 Motor	Capacity Curve

COMPRESSOR # 46-13484 MOTOR DRIVEN SINGLE ENDED 6K PSI

46-13484	Compressor Assembly Sheet
84001000200	Head & Drive Piston Assembly
84001000300	Head Assembly 6,000 PSI
84001000400	Drive Piston Assembly
44-11102	Intake Check Valve 10,000 PSI
44-11107	Discharge Check Valve 10,000 PSI
44-14110	Intake Check Valve 40,000PSI
62006001200	Assembly Relief Valve-Liquid Service
Curve 6k Motor	Capacity Curve

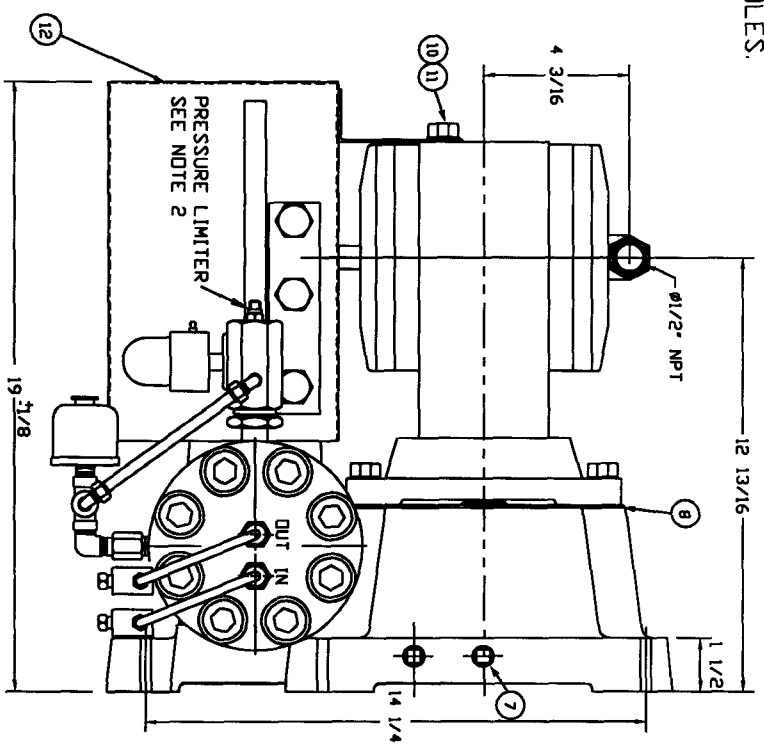
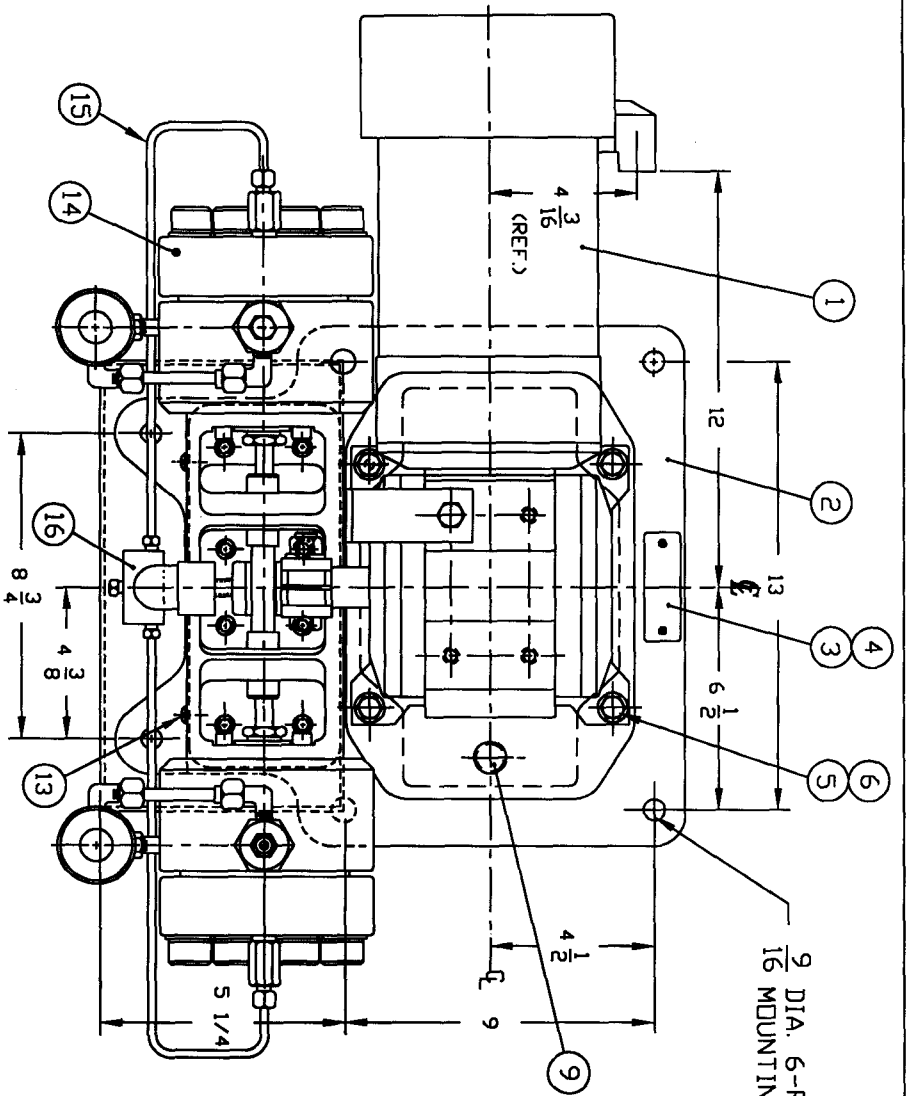

ITEM No.	REQ'D	DESCRIPTION	DWG SIZE	PART No.	MATERIAL
16	2	TEE, 1/4 HP	C	45-14311	AS PER DETAILS
15	4	TUBING - INTAKE & EXHAUST	B	64042001800	TYPE 304 ST. ST.
14	1	HEAD & DRIVE ASSEMBLY, DOUBLE ACTING	D	64042002902	AS PER DETAIL
13	2	BINDING HD. MACH. SCREW No. 10-32 x 3/8 LG.		80765018615	BRASS N.P.
12	1	GUARD	D	63173010600	STEEL
11	1	HEX. CAP MACH. SCREW 1/2-13 x 3/8 LG.		2125-705 01850024915	STEEL
10	1	FLAT WASHER 1/2		R1065008200	STEEL
9	1	PLUG. K.D. BOX SNAP IN BLANK 3/4 SPRING TYPE COVER		P0417023500	BRASS N.P. POLISHED.
8	1	COVER	C	63173002100	AL.
7	3	PLUG, 1/4 NPT.		P0205000100	BRASS
6	4	FLAT WASHER, 3/8	A	63167001300	STEEL
5	4	HEX. CAP MACH. SCREW 3/8-16 x 1 1/2 LG.		2123-724 01850013934	STEEL
4	2	BINDING HD. SHEET MET. SCR. No. 2-56 x 1/8 LG.		3302-302 02240031107	STEEL
3	1	NAME PLATE	A	630700005200	AL.
2	REF	BASE		63173002000	
1	1	MOTOR RELIANCE. XL GEAR, RIGHT ANGLE REDUCTION, 1-HP, 58 RPM, FRAME. X56-WM21B		POS52005400	

LIST OF MATERIAL

NOTES:-
 1. COMPRESSOR BASE MUST BE BOLTED TO A FLAT SOLID SURFACE.
 2. SET PRESSURE LIMITERS TO 10,500 PSI.
 3. MOTOR OUTPUT SHAFT TO RUN IN A COUNTERCLOCK DIRECTIONAL ROTATION.
 4. REPLACES D46-13421.

UNLESS OTHERWISE SPECIFIED DIMENSIONS ARE IN INCHES TOLERANCES: FRACTIONS ± 1/64 DECIMALS ± ANGLES ± REMOVE ALL BURRS AND SWAGE EDGES DO NOT SCALE THIS DRAWING

BY: NAME DATE FINISH: 5-4-84

CHECKED: DATE APPROVED: DATE

MATERIAL AS NOTED

SCALE NONE WEIGHT SHEET 1 OF 1

MPLE MOTOR DRIVEN-DOUBLE END DIAPHRAGM COMPRESSOR 10,000 PSI. 9/16 DIA. PISTON 59505 CODE DENT. NO. 0 PART NO. 46-13421-2 DRAWING NO. 46-13421-2

NEERPORT SCIENTIFIC INC.

PROPRIETARY This document is issued in strict confidence and its content, reproduction or disclosure to a third party, wholly or in part, without written consent of Neerport Scientific, Inc.

NOTE:
POSITION OF THIS CRANK (ITEM 10),
WHEN SLOTTED LEVER
IS AT A 90° POSITION
AS SHOWN WITH PHANTOM
LINES ON FRONT VIEW

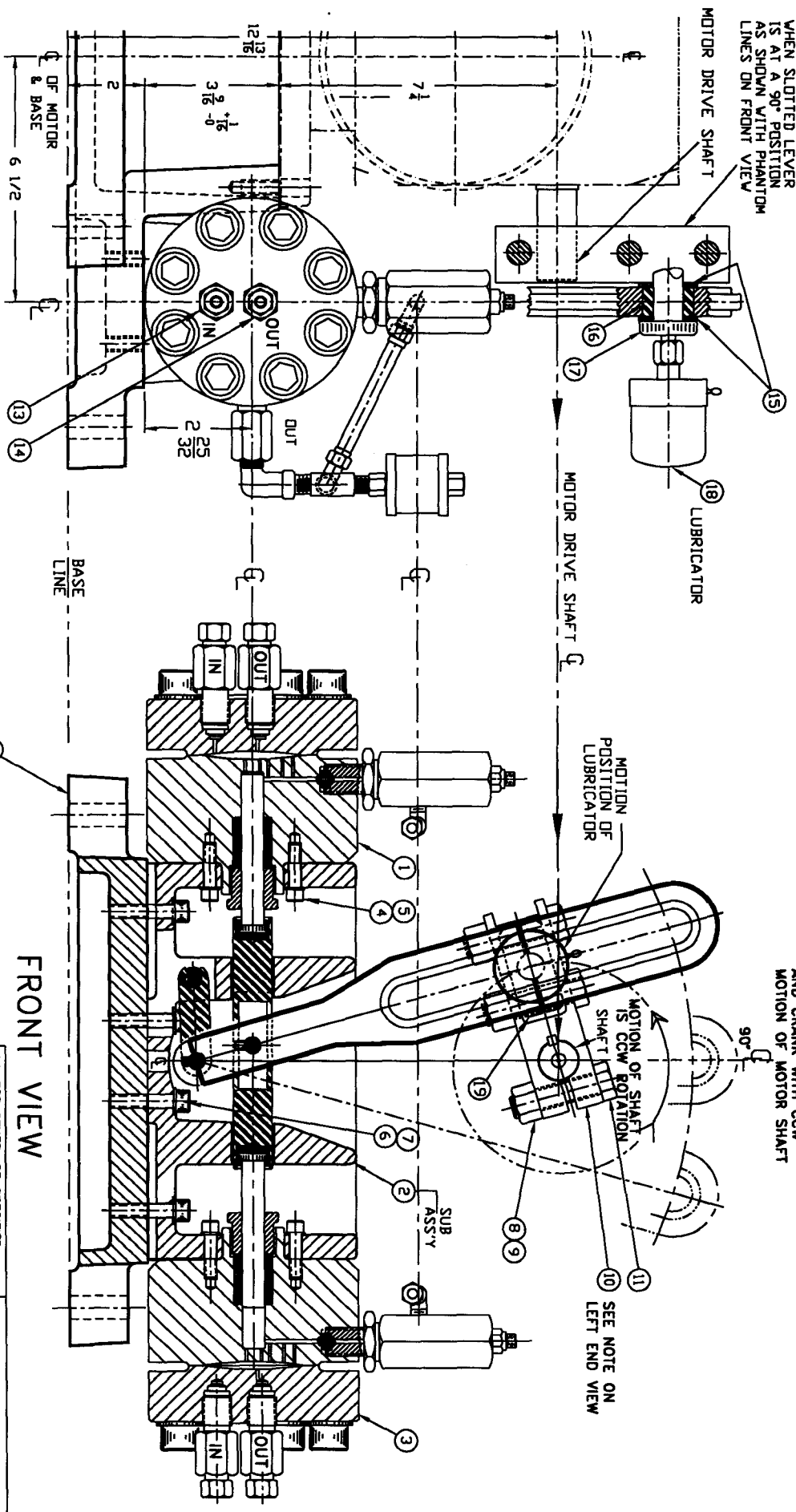

LEFT END VIEW

FRONT VIEW

LAYOUT OF SLOTTED LEVER
AND CRANK WITH CCW
MOTION OF MOTOR SHAFT

MOTION OF
POSITION OF
LUBRICATOR

MOTION OF SHAFT
IS CCW ROTATION

SEE NOTE ON
LEFT END VIEW

NOTE:
1 — FOR PARTS NOT SHOWN, SEE FINAL
INSTALLATION DWG. NO. 46-13421-2.

UNLESS OTHERWISE SPECIFIED DIMENSIONS ARE IN INCHES TOLERANCES:		<p>PROPRIETARY</p> <p>This document is issued in strict confidence on condition that it is not copied, reprinted, or disclosed without the prior written consent of Newport Scientific Inc.</p>
<p>FRACTIONS ±</p> <p>DECIMALS ±</p> <p>ANGLES ±</p> <p>REMOVE ALL BURRS AND SHARP EDGES</p> <p>DO NOT SCALE DRAWING</p>		
BY:	NAME:	<p>FINISH:</p> <p>NEPROPT SCIENTIFIC INC.</p>
CHECKED:	DATE:	
APPROVED:		
MATERIAL FOR LIST OF MAT'L.		
SEE: SHEET 2		
SCALE: NONE	INCHES	
<p>MOTOR DRIVEN DOUBLE END DIAPHRAGM COMPRESSOR 10,000 PSI. 9/16 DIA. PISTON HEAD & DRIVE PISTON ASSEMBLY</p>		
CODE ORGT. NO.	SIZE	
58505	D	
PART NO. 64042002902	DRAWING NO. 29640422	
SHEET 1 OF 2		

46-13421-2	USED ON
NEXT ASSY	
APPLICATION	

REVISION		
LTR	DESCRIPTION	DATE

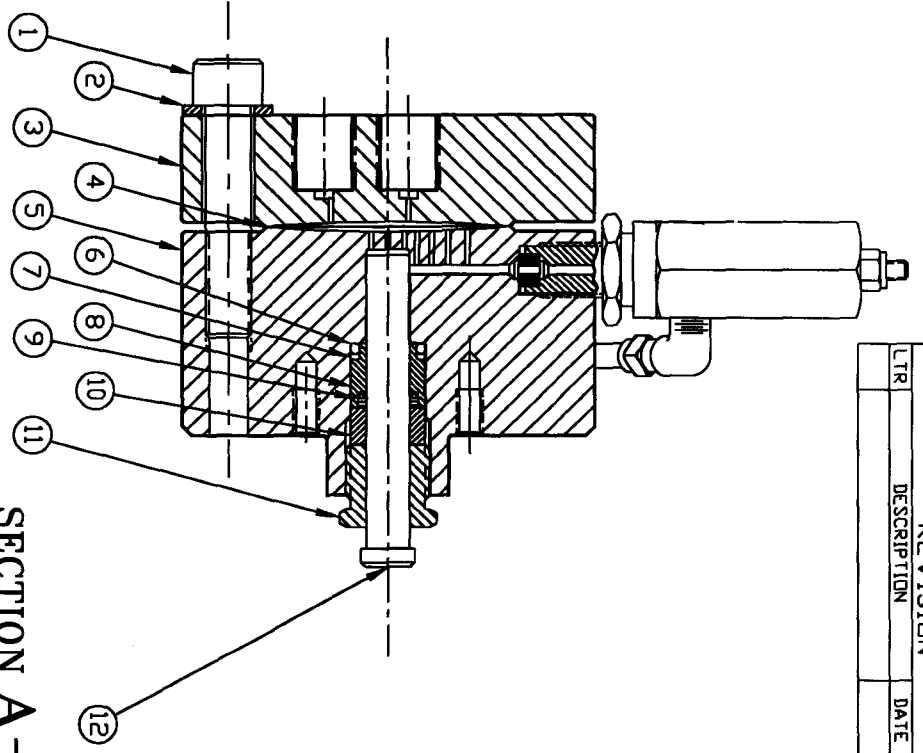
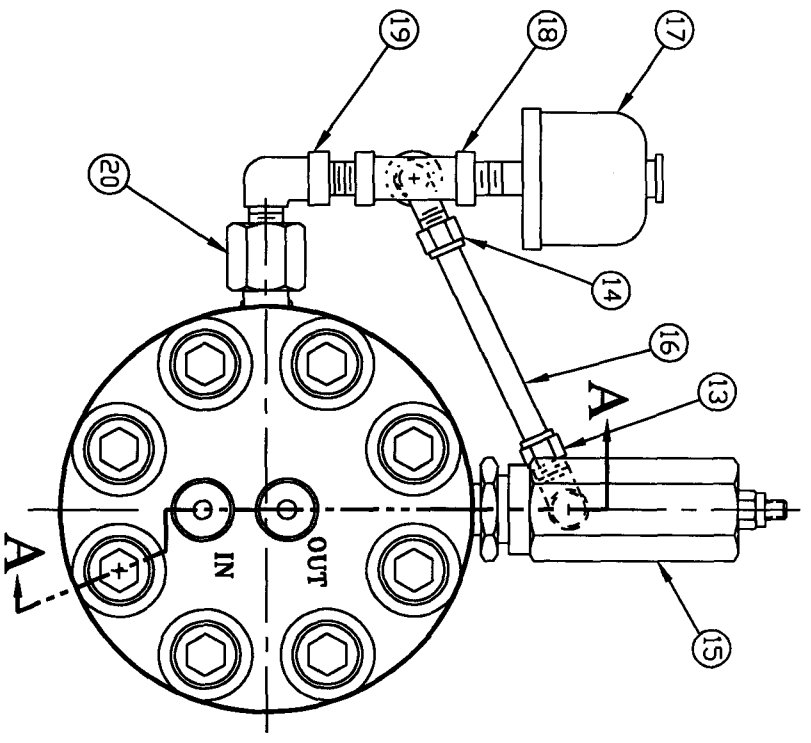

SECTION A-A

NOTES:
1. MARK OR TAG WITH ASSEMBLY NO.

ITEM	QTY.	DESCRIPTION	PART/DWG. NO.	MATERIAL
20	1	CHECK VALVE, HYDRAULIC	44 14110	PER ASSEMBL.
19	1	ELBOW, 90° STREET TYPE	P0201004100	BRSS
18	1	TEE, 1/4 NPT.	P0201060100	BRSS
17	1	OILER	P1004003000	AS PER DETAILS
16	0.5	TUBING, 1/4 IN. O.D. X 4.5	P1245000100	COPPER
15	1	PRESSURE LIMITER	62006001201	PER ASSEMBLY
14	1	ELBOW, 90° COMPRESSION TYPE	P0215025100	BRSS
13	1	ELBOW, 90° COMPRESSION TYPE	P0215025400	BRSS
12	1	PISTON, 9/16 IN. DIAMETER	64042002300	440C ST. STEEL
11	1	GLAND NUT	64042002400	416 ST. STEEL
10	1	PROCKING FOLLOWER	64042002200	ALUM. BRONZE
9	1	PROCKING	P1615009000	MOLYTHANE
8	1	PROCKING RETAINER	64042002500	ALUM. BRONZE
7	1	BRCK-UP RING	P1620009600	BLUM-N
6	1	O-RING	P1604011000	BLUM-N
5	1	BODY	64042003102	CHROME-VAN. STEEL
4	1	DIPPRPM	62018000500	302 ST. STEEL
3	1	HEAD PLATE	62018001000	17-4PH ST. STEEL
2	8	WASHER, PLAIN 21/32 I.D. X 1/8 THICK	P16334041400	STEEL
1	8	SCREW, 5/8-18UNF-2H X 3, SOC. HD, CPF	P02030074800	STEEL

LIST OF MATERIAL

73064000202	48-13427-2	48-13421-2	48-13421-2
64042002902	48-13421-2	48-13421-2	48-13421-2
APPLICATION	USED ON	NEXT ASSY	

UNLESS OTHERWISE SPECIFIED DIMENSIONS ARE IN INCHES TOLERANCES: FRACTIONS ± DECIMALS ± ANGLES ± REMOVE ALL BURRS AND SHARP EDGES DO NOT SCALE THIS DRAWING	<p>PROPRIETARY</p> <p>This document is issued in strict confidence on condition that it is not copied, reprinted or disclosed to a third party, wholly or in part without written consent of Newport Scientific Inc.</p> <p>NEWPORT SCIENTIFIC INC.</p>
<p>HEAD ASSY, RIGHT SIDE, 10,000 PSI MOTOR DRIVEN DIAPHRAGM COMPRESSOR, 9/16 DIA PISTON</p>	<p>CODE IDENT. NO. 59505</p> <p>PART NO. 64042002602</p> <p>DRAWING NO. 26640422</p>
<p>PREPARED BY: _____ DATE: _____</p> <p>CHECKED BY: _____ DATE: _____</p> <p>APPROVED BY: _____ DATE: _____</p>	<p>FINISH: _____</p> <p>SCALE: _____</p> <p>WEIGHT: _____</p> <p>SHEET 1 OF 1</p>

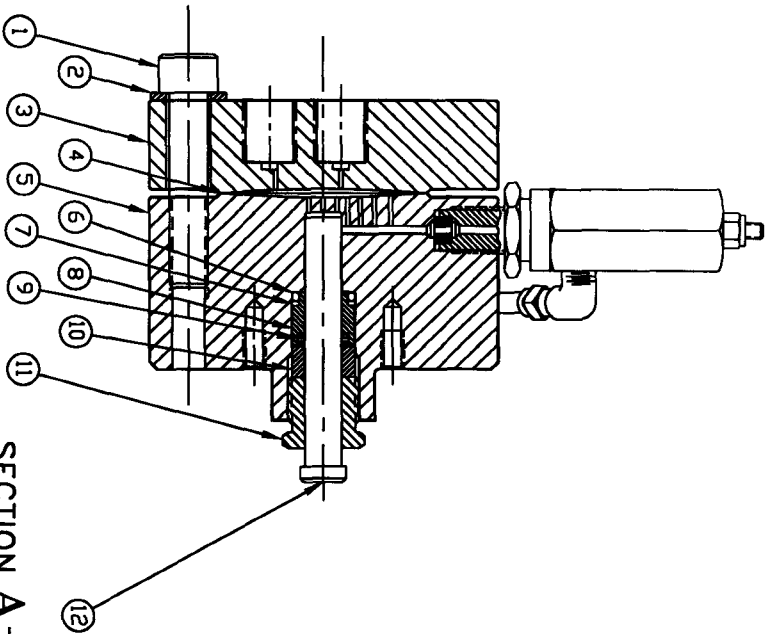
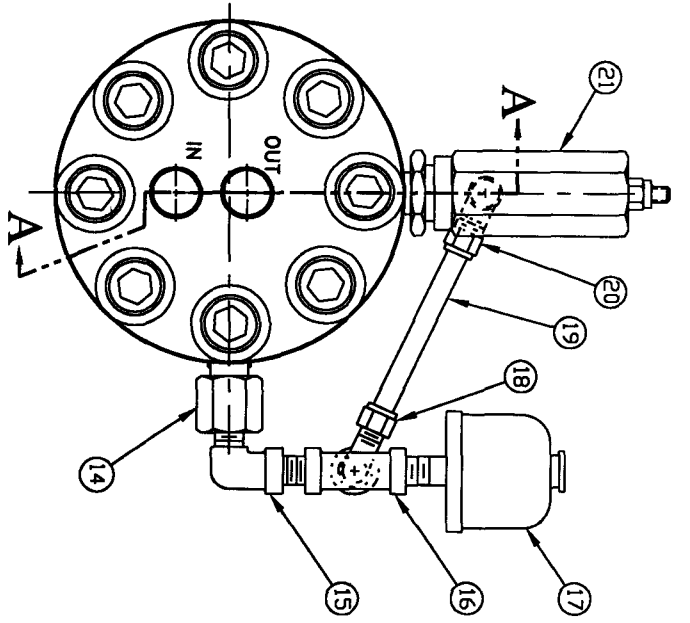

SECTION A-A

NOTE:
1. MARK OR TAG WITH ASSEMBLY NUMBER

ITEM	QTY	DESCRIPTION	PART NO.	MATERIAL
21	1	RELIEF VALVE - ASSEMBLY	62006001201	AS PER DETAILS
20	1	90° ELBOW, COMPRESSION 1/8 NPTM X 1/4 O.D. TUBING	P0215025100	BRASS
19	0.5	TUBING 1/4 O.D. X 6' LONG, APPROX. .035V	P1245000100	BRASS
18	1	90° ELBOW, COMPRESSION 1/4 NPTM X 1/4 O.D. TUBING	P0215025400	BRASS
17	1	OILER, *TRICID* TYPE PC # 40081	P1004002900	AS PER DETAILS
16	1	STREET TEE 1/4 NPTF X 1/4 NPT MALE RUN	P0201060100	BRASS
15	1	90° STREET ELBOW 1/4 NPTM X 1/4 NPTF	P0201004100	BRASS
14	1	CHECK VALVE VALVE, INTAKE (OIL SIDE)	44-14110	AS PER DETAILS
13	—	NOT USED		
12	1	PISTON 9/16 DIA.	64042002300	TYPE 440 C.S.T.ST.
11	1	PACKING GLAND NUT	64042002400	TYPE 416 S.T.ST.
10	1	PACKING FOLLOVER	64042002200	AMPCD # 15
9	1	POLYPAK SEAL PACKING	P1615009000	MOLYTHANE
8	1	PACKING RETAINER	64042002500	AMPCD # 15
7	1	BACK-UP RING (8-210-N300-9)	P1620009600	BUNA -N*
6	1	*O* RING (2-210)	P1604011000	BUNA -N*
5	1	BODY	64042003102	4340 HR HT
4	1	DIAPHRAGM	62018000500	TYPE 302 S.T.ST.
3	1	HEAD	62018001000	TYPE 17-4 PH.S.S.
2	8	WASHER, PLAIN 21/32 I.D. X 1/8 THICK	P1634041400	STEEL, HARDENED
1	8	SCREW, SOCKT HD. CAP, 5/8-18UNF-2A X 3' LONG	P2030074800	STEEL, B.L. DX.

LIST OF MATERIAL

APPL ASSY	27-64042-2	46-13421-2	46-13411-2	USED ON
APPLICATION				
SEE SH 2				
SCALE: NONE	CODE IDENT. NO. 59505	SIZE D	DRAWING NO. 64042002802	SHEET 1 OF 1
UNLESS OTHERWISE SPECIFIED DIMENSIONS ARE IN INCHES TOLERANCES: FRACTIONS ± DECIMALS ± ANGLES ±0°-30° REMOVE ALL BURRS AND SHARP EDGES DO NOT SCALE THIS DRAWING		PROPRIETARY This document is issued in strict confidence on condition that it is not copied, reprinted, or in part, without written consent of Newport Scientific, Inc.		
FINISH: BY: _____ CHECKED: _____ DRAWN: _____ APPROVED: _____ DATE: _____		NEWPORT SCIENTIFIC INC. MOTOR DRIVEN DIAPHRAGM COMPRESSOR 10,000PSI. LEFT SIDE HEAD ASSEMBLY 9/16 DIA. PISTON		

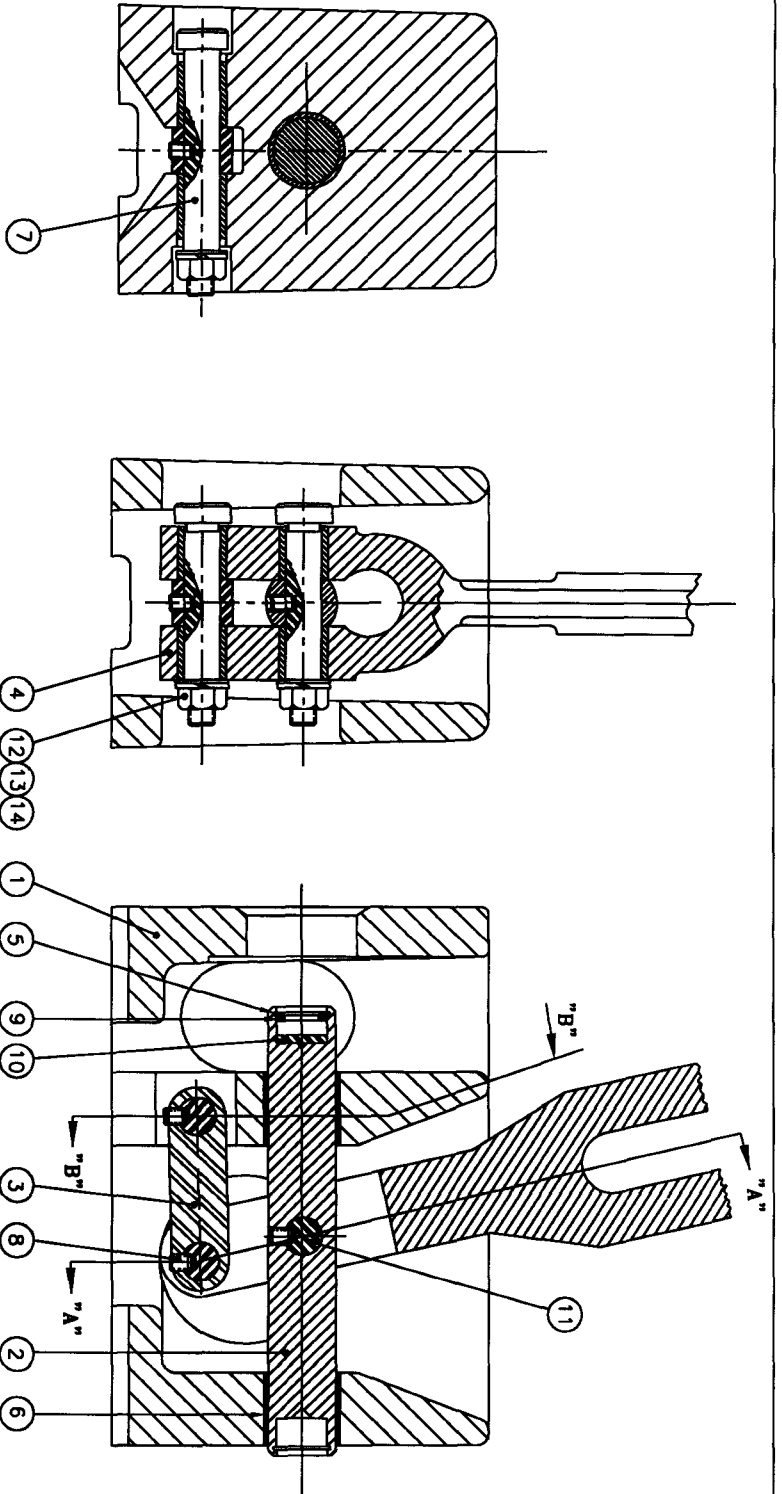

SECTION B -- B SECTION A -- A

ITEM NO.	REQ.	DESCRIPTION	PART NO.	MATERIAL
14	3	LOCK WASHER 3/8 I.D.	R1061005400	STEEL
13	3	FLAT WASHER 3/8 I.D.	R1065007200	STEEL BL. OX.
12	3	HEX. NUT 3/8 - 16	R1050001500	STEEL, CAD. PL.
11	2	SHOULDER SCR. 1/20MAX 1/4 LG	63167004000	STEEL
10	1	THRUST WASHER	63167002500	TYPE 416 ST. ST.
9	1	"C" RING	84001001300	TYPE 316 ST. ST.
8	3	SET SCREW 1/4-28X1/4LG HALF DOG POINT	P1020021300	ALLOY STEEL, BL. OXIDE
7	1	SHOULDER SCR. 1/2 DMAX LG.	63167004100	STEEL
6	2	BEARINGS (REF.)	1500-250	NYLON AND STEEL
5	1	RETAINING RING	P1620021800	STEEL
4	1	SLOTTED LEVER	63173010100	STEEL
3	1	LINK	63173010400	CARBON STEEL
2	1	DRIVE PISTON	63173010300	ALLOY STEEL
1	1	BASE	63167004300	ALUM. ALLOY

LIST OF MATERIAL

PREPARED	DATE	FINISH:	<p>UNLESS OTHERWISE SPECIFIED DIMENSIONS ARE IN INCHES FRACTIONS ± DECIMALS ± ANGLES ± 0-30° REMOVE ALL BURRS AND SHARP EDGES DO NOT SCALE THIS DRAWING</p>	<p>PROPRIETARY This document is issued in strict confidence on condition that it is not copied, reprinted, or disclosed to a third party, wholly or in part, without written consent of Newport Scientific Inc.</p>
CHECKED				
ENGR/DSCH				
APPROVED				
MATERIAL			<p>SCALE: 59505</p>	<p>WEIGHT: SHEET 1 OF 1</p>
NEXT ASSY USED DN		APPLICATION	SEE CHART	<p>TITLE: DRIVE PISTON-ASSEMBLY SINGLE ACTING, MOTOR DRIVEN</p> <p>CODE IDENT. NO. 59505</p> <p>PART NO. 84001000400 DRAWING NO. 484001</p>



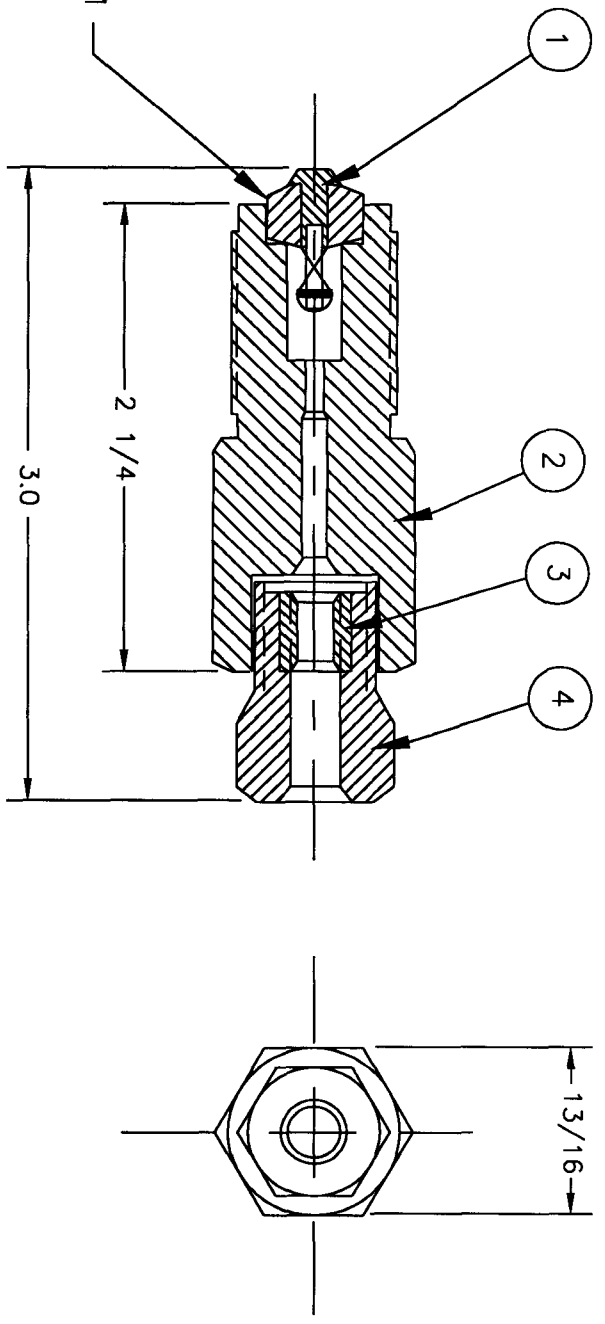

NOTES:

1. STAKE LENS RING OF POPPET; SUB-ASSEMBLY ITEM 1 IN PLACE WITH CENTER PUNCH IF NECESSARY.
2. TIGHTEN GLAND NUT ITEM 4 HAND TIGHT FOR SHIPPING.
3. TIGHTEN GLAND NUT ITEM 4 TO A TORQUE OF 15 FT./LBS. APPROX. WITH TUBING INSTALLED.
4. PRESS. RATING = 10,000 P.S.I.
5. ELECTRO ETCH/MARK
 - A. SUPERPRESSURE DIAMOND
 - B. CAT NO.
 - C. PRESSURE RATING (IF APPLICABLE)
 - D. LOT NO. (IF APPLICABLE)
 - E. D.O.M.
 - F. FLOW ARROW (IF APPLICABLE)

ITEM	QTY.	DESCRIPTION	PART NO	MATERIAL
1	1	POPPEI: SUB-ASSEMBLY	66005000100	AS PER DETAIL
2	1	VALVE BODY	62004001000	TYPE 316 ST. STL.
3	1	INNER SLEEVE	45-11316	TYPE 416 ST. STL.
4	1	GLAND NUT	45-11313	TYPE 416 ST. STL.

NEXT ASSY		USED ON	
APPLICATION			
UNLESS OTHERWISE SPECIFIED DIMENSIONS ARE IN INCHES			
TOLERANCES:			
FRACTIONS ±			
DECIMALS ±			
ANGLES ±			
REMOVE ALL BURS AND SHARP EDGES			
DO NOT SCALE THIS DRAWING			
BY	NAME	DATE	FINISH:
CHECKED			
DRAWN/ISSUED			
APPROVED			
TITLE		GAS SERVICE	
CHECK VALVE 10,000 PSI INTAKE		SOFT SEAT	
CODE IDENT. NO.	SIZE	PART NO.	DRAWING NO.
59505		44-11102	4411102
SCALE	WEIGHT	SHEET OF	

PROPRIETARY

This document is issued in strict confidence on condition that it is not copied, reprinted, or disclosed in any form without the written consent of Newport Scientific Inc.

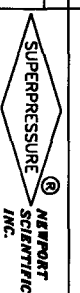

ELECTRO ETCH/MARK

- A. SUPERPRESSURE DIAMOND
- B. CAT NO.
- C. PRESSURE RATING (IF APPLICABLE)
- D. LOT NO. (IF APPLICABLE)
- E. D.O.M.
- F. FLOW ARROW (IF APPLICABLE)

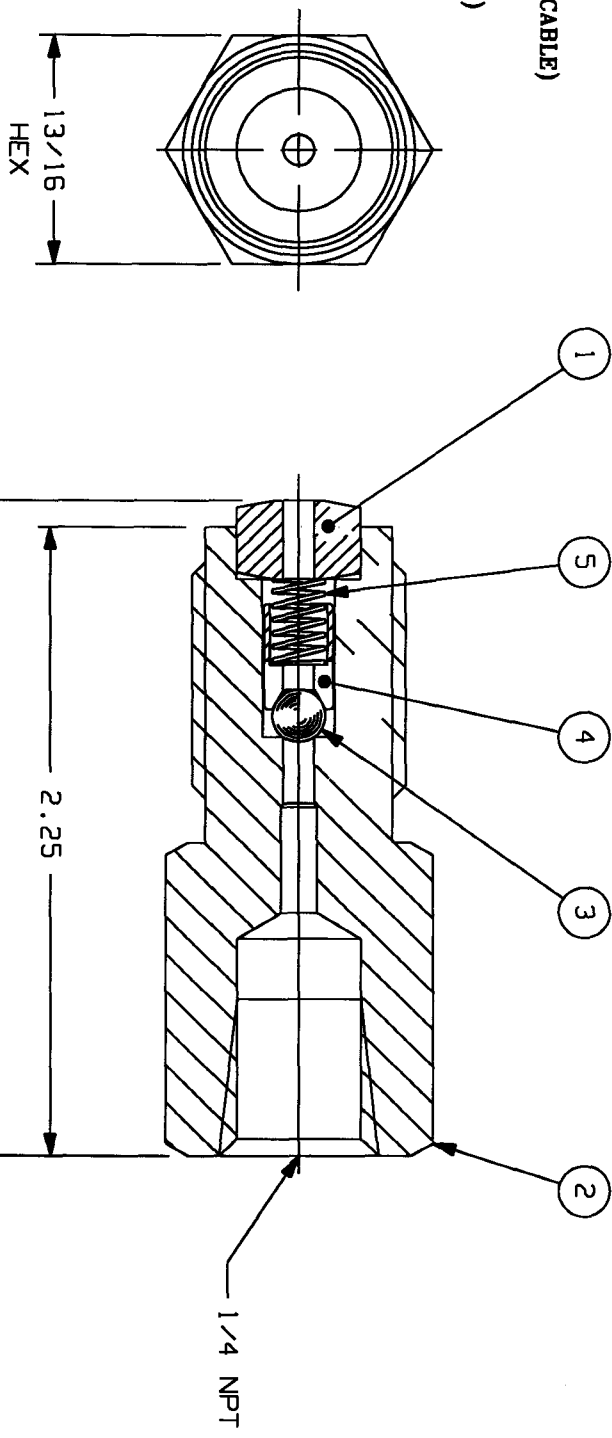

ITEM	QTY	DESCRIPTION	DWG/PART NO.	MATERIAL
5	1	SPRING	50029003204	TYPE 18-8 STAINLESS STEEL
4	1	BALL RETAINER	62002000400	TYPE 316 STAINLESS STEEL
3	1	BALL	P1500013300	TYPE 440 STAINLESS STEEL
2	1	BODY	62079000400	TYPE 316 STAINLESS STEEL
1	1	LENS RING	63038000400	TYPE 17-4PH STAINLESS STEEL

LIST OF MATERIAL

NOTES:

1. STRIKE ITEM 1 (LENS RING) IN PLACE WITH A CENTER PUNCH IF NECESSARY.
2. DIMENSIONS SHOWN ARE FOR REFERENCE ONLY

PROPRIETARY

This document is issued in strict confidence on condition that it is not copied, reprinted, or disclosed to a third party, wholly or in part, without written consent of Newport Scientific Inc.

UNLESS OTHERWISE SPECIFIED DIMENSIONS ARE IN INCHES TOLERANCES: FRACTIONS ± SEE DECIMALS ± NOTES ANGLES ± REMOVE ALL BARS AND SWAMP EDGES DO NOT SCALE THIS DRAWING MATERIAL:		CONTRACT BY NAME DATE PREPARED CHECKED ENGR/DSGN APPROVED CERTIFICATION		 NEPORT SCIENTIFIC INC. LIQUID SERVICE CHECK VALVE 40,000 PSI INTAKE	
SEE MATERIAL LIST	CODE IDENT. NO. S9505	SIZE	PART NO. 44-14110		
NEXT ASSY. APPLICATION	USED ON	SCALE	WEIGHT	SHEET 1 OF 1	

REVISIONS			
SYM	DESCRIPTION	DATE	APPROVED
A	ADDED ITEM #10	10-2-01	

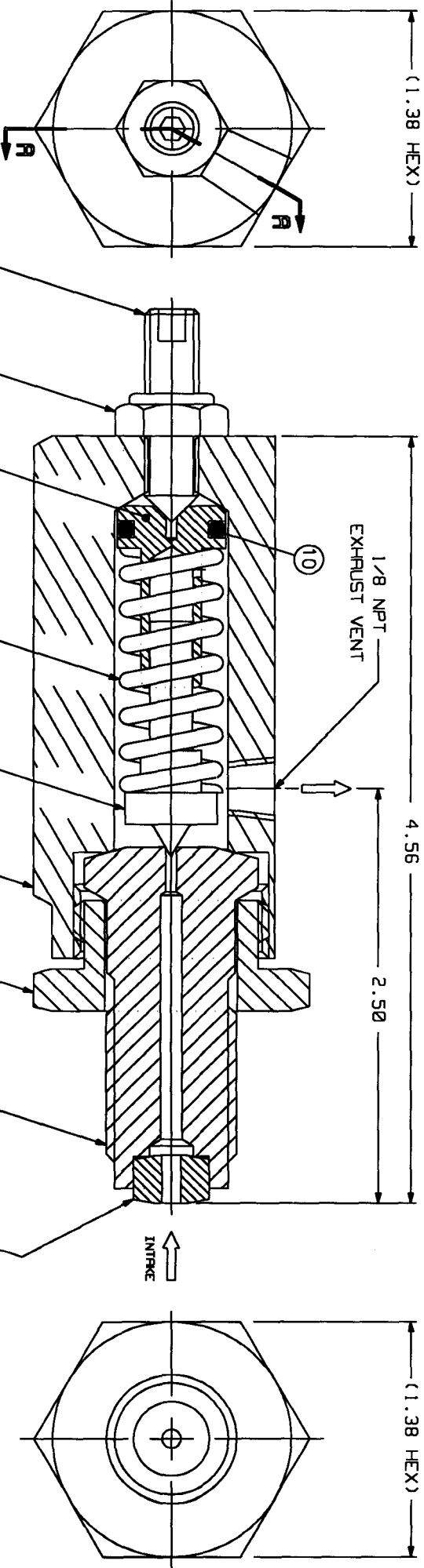

ITEM NO.	ORIFICE DIA	PRESSURE RANGE (PSI)
-4	.125	3,000 - 7,500
-3	.046	20,000 - 50,000
-2	.062	14,000 - 35,000
-1	.093	5,000 - 14,000

SECTION R-R

**STAMP PART NO.
AND D.O.M.**

REPLACES
DRAWING NO.
B1-62006

APPLICATION
NEXT ASSY USED ON

ITEM	QTY	DESCRIPTION	DMG/PART NO.	MATERIAL
10	1	"O" RING	P1604025100	BUNA "N"
9	1	STOP NUT, THIN ELASTIC, 5/16-24UNF-2B	P1054005500	STEEL
8	1	GASKET, LENS RING	63038000400	17-4 PH STEEL
7	1	VALVE SEAT (SEE CHART)	62006001000	17-4 PH STEEL
6	1	NUT	62006001100	CRS
5	1	BODY	62006000900	CRS
4	1	STEM	64079000200	440C STAINLESS STEEL
3	1	SPRING	P1632014900	ALLOY STEEL
2	1	GUIDE, SPRING	64079000300	416 STAINLESS STEEL
1	1	SET SCREW, SOCKET HD, 5/16-24UNF-2R	62006000800	STEEL

LIST OF MATERIAL

UNLESS OTHERWISE SPECIFIED
DIMENSIONS ARE IN INCHES
TOLERANCES:
FRACTIONS ±
DECIMALS ± .03
ANGLES ±

REMOVE ALL BURS AND SHARP EDGES
DO NOT SCALE THIS DRAWING

BY: _____ DATE: _____
PREPARED: _____
CHECKED: _____
DATE/DRAWN: _____
APPROVED: _____
MATERIAL: _____

PROPRIETARY
This document is issued in strict confidence on condition that it is not copied, reprinted, or disclosed to a third party, wholly or in part, without written consent of Newport Scientific Inc.

NEPORTE SCIENTIFIC INC.
SUPERPRESSURE

ASSEMBLY
RELIEF VALVE FOR
LIQUID SERVICE

TITLE

CODE IDENT. NO. 59505
PART NO. 62006001200
DRAWING NO. 1262006

SCALE 2=1 WEIGHT SHEET 1 OF 1

SEE CHART

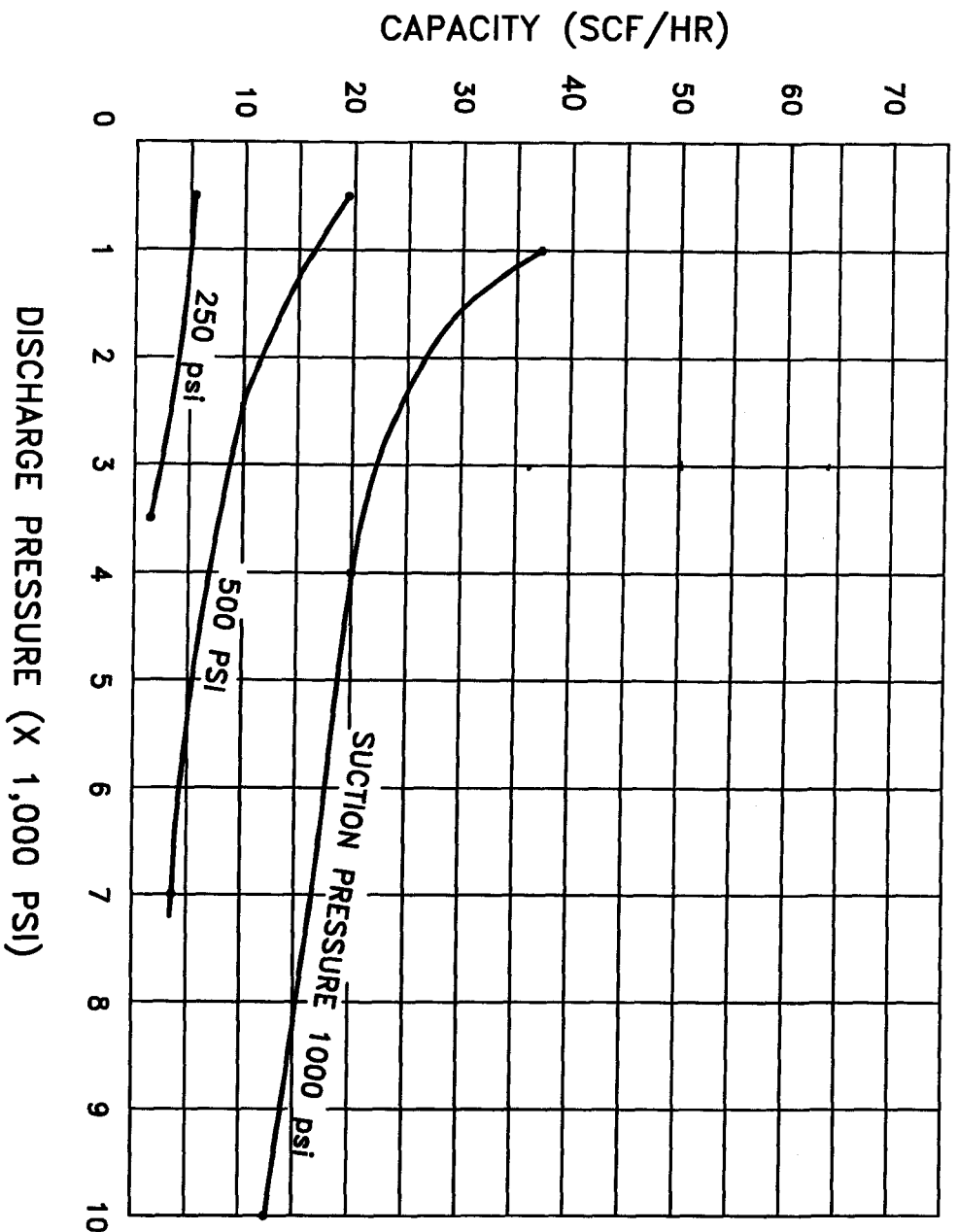

CAPACITIES FOR DOUBLE END
 UNIT No.46-13421-2 ARE
 APPROX. 2 TIMES FOR THE
 SINGLE END UNIT 46-13411-2

TEST DATA
 GAS : NITROGEN
 TEMPERATURE : 70°F
 OIL : SAE 20

DISCHARGE PRESSURE (X 1,000 PSI)

UNLESS OTHERWISE SPECIFIED
 DIMENSIONS ARE IN INCHES
 TOLERANCES:
 FRACTIONS ±
 DECIMALS ±
 ANGLES ±
 REMOVE ALL BURRS AND SHARP EDGES
 DO NOT SCALE THIS DRAWING

BY: [] NAME: [] DATE: []
 PREPARED: []
 CHECKED: []
 DRAWN/ISSUED: []
 APPROVED: []
 MATERIAL: []

FINISH: []
 CODE IDENT. NO. 59505
 SIZE [] PART NO. CURVE 10K MDT
 DRAWING NO. CURV10KMDT

SCALE [] WEIGHT [] SHEET [] OF []

PROPRIETARY
 This document is issued in strict confidence on condition that it is not copied, reprinted, or disclosed to a third party, wholly or in part, without written consent of Newport Scientific Inc.

SUPERPRESSURE®
 NEWMPORT SCIENTIFIC INC.

**CURVE FOR SINGLE END
 10K PSI MOTOR DRIVEN #46-13411-2**

NEXT ASSY [] USED ON [] APPLICATION []